

# PVC Turbine Meter Installation and Operation

These PVC turbine meters have only one moving part; a precision machined helical rotor. Rotation of the rotor is electronically detected and processed. Precision bearings provide long life, and the entire rotor assembly can be easily removed without removing the meter from the pipe.

---

## Installation

### Piping Conditions

In general, we recommend the standard practice of installing the meter with ten diameters of straight pipe upstream and five downstream. However, it is possible under some circumstances to operate with less, particularly if the meter is equipped with an optional flow straightener.

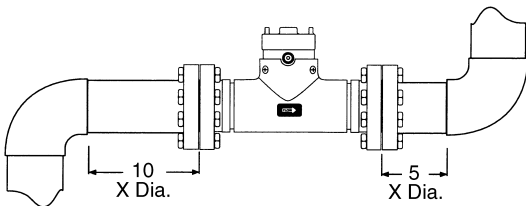

### Flanges

For these meters you should use 150# round water companion flanges. You should install the meters following the manufacturer's recommended bolt torque. A bolt torque of 10-20 ft. lb. for 2", 20-30 ft. lb. for 3" and 4", and 35-50 ft. lb. for 6" and 8" is recommended. Tighten the bolts evenly, using either partial or full-face gaskets. Use care to prevent a misarranged gasket from entering the flow stream.

### Position

These meters are all position meters. You may install them in a vertical or horizontal position, and with the meter in any radial position. We recommend a horizontal

position if there is a risk of air becoming trapped due to constant low flows. Operating the meter in a partially filled pipe will result in inaccuracies.

### Connections

See the manual for the meter controller which came with your system.

---

## Operation

See the manual for the meter controller which came with your system.

---

## Maintenance and Repair

### Turbine Insert Removal and Installation

In order to repair any mechanical parts (rotor or shafts) you must remove the turbine insert. To do this, first shut off the water and relieve the water pressure from the line. Then remove the screws which hold the insert in place. The 2" meters use a U shaped retaining pin; all others have four screws. Tug gently on the insert until it comes free. A twisting motion will help loosen the O-ring seal. When reinstalling, coat the O-Ring with a plastics-compatible lubricant. Do not over tighten the screws. It is sufficient to just tighten them snugly with a hand screwdriver.

### Rotor and shaft Replacement

Examine the rotor to determine if bearings or shaft are damaged or excessively worn. The rotor should spin smoothly and freely, with no visible wobble. Back and forth play should be very minor, less than  $\frac{1}{64}$ ". If it is necessary to replace the rotor or shafts, first back out both shafts with a small blade screwdriver. The rotor will come free as soon as the shaft ends come free of the rotor bearings.

## Sensor Assembly Replacement (P/N 18110)

This procedure is rarely necessary. However, certain electrical conditions can damage the sensor. first make note of how the wires are connected to the terminal block (Write it down) and disconnect the wires. Remove the screws holding the sensor circuit board, and unscrew the sensor retaining ring screw. Then unscrew the sensor retaining ring. Pull on the sensor leads to remove the sensor; a gentle tug should be sufficient. Replace the sensor by reversing the process.

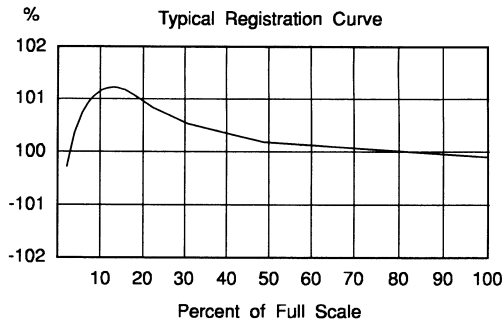
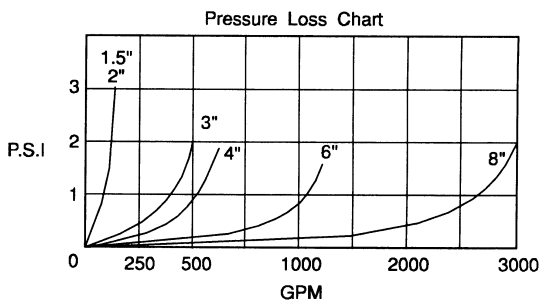
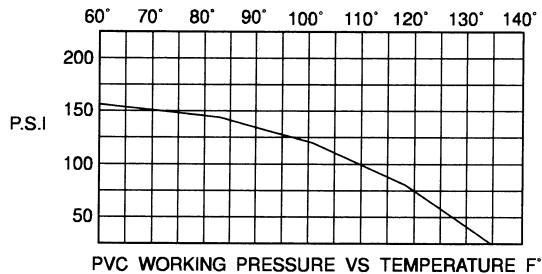

## Specifications

### Materials

Meter Body PVC Schedule 80 fittings

Turbine insert PVC (machined)

Turbine rotor Acetyl plastic

Shafts Tungsten Carbide

### Bearings

Sapphire journal

### Pressure

150 PSI @ 75° F (see chart)

### Temperature

140° F max. (see chart)

### Accuracy

1.5% Full scale

(When meter controller is set to K factor marked on meter)

Size	2"	3"	4"	6"
<b>Flow Range (GPM)</b>				
<b>Min.</b>	2	3	6	12
<b>Max.</b>	150	400	600	1200
<b>Meter Size &amp; Shipping Wt.</b>				
<b>Dim. A</b>	6 <sup>3</sup> / <sub>4</sub> "	6 <sup>1</sup> / <sub>2</sub> "	7"	8 <sup>1</sup> / <sub>2</sub> "
<b>Dim. B</b>	10"	12"	14"	18"
<b>Wt. (lb.)</b>	10	14	18	27

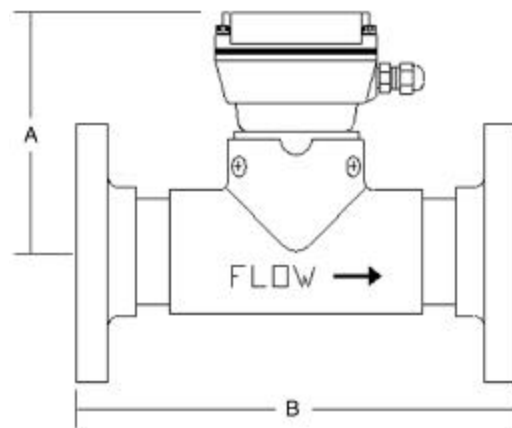

# PVC Precision Flow Meter

## Complete Meters

16609	2 Inch
16610	3 Inch
16621	4 Inch
16632	6 Inch

