



Figure 1
J Plus Controller

UNPACKING

Please open and inspect your package upon receipt. Your package was packed with great care and all the necessary packing materials to arrive to you undamaged. If you do find an item that is broken or damaged, you must contact the delivering carrier to report the claim.

Ratio Feeder®

Series J Plus Pumper Controllers

GETTING TECHNICAL ASSISTANCE

The H.E. Anderson Company is dedicated to assisting our customers with installation and use of our products. Our technical staff are available each weekday from 8:30am to 4:30pm central time. You may call us toll free at **1-800-331-9620** from anywhere in the U.S.A.. and Canada. If no one is available, we will promptly return your call.

Before you call, we suggest that you review this manual. You may find the answer to your question here. But even if you do not, reviewing the manual will help us to help you.

There is some information you should have available when you call. You should know the program number and serial number of your control unit. Also, you should note the number of pumpers of each type, and their model numbers. We may not need all this information, but having it available at the start can some times save a lot of time and trouble for you. You may record the information be low for convenient reference. **NOTE:** The program number can be displayed by pressing both the **↑** and **↓** keys together.

SERIAL _____	PROGRAM NUMBER _____
PUMPER #1 _____	PUMPER #6 _____
PUMPER #2 _____	PUMPER #7 _____
PUMPER #3 _____	PUMPER #8 _____
PUMPER #4 _____	PUMPER #9 _____
PUMPER #5 _____	PUMPER #10 _____

If you need an additional owners manual for any H.E. Anderson Company product, please visit our website at <http://heanderson.com/manuals.php>



J PLUS QUICK START INFORMATION

MODEL NO. _____ SERIAL NO. _____

Do all wiring before connecting power. Use a surge suppressor on the incoming AC power line. Plug in the power cord and watch the LCD display. If it does not come on, unplug the power and check the wiring.

This unit was ordered with the following capacities or settings:

Customer Requested _____ Default _____
 Program Number _____
 K Factor _____ [Pulses per unit volume (gallons or liters)]
 Maximum Flow _____
 VPS* #1 _____ *VPS = Volume Per Stroke (gallons or liters)
 VPS #2 _____
 VPS #3 _____
 VPS #4 _____

With the above settings, pumpers will have the following chemical to water feed ratio capacities (At dial setting 10).

BASE #1 = (VPS #1 x N) ÷ 80 = _____ N=3785(gal.), N=1000(liters)

H8	1: _____ (BASE #1)	H4, P4	1: _____ (BASE #1 x 2)
H2, P2	1: _____ (BASE #1 x 4)	H1, P1, A10	1: _____ (BASE #1 x 8)
A3	1: _____ (BASE #1 x 26.7)		

BASE #2 = (VPS #2 x N) ÷ 80 = _____

H8	1: _____ (BASE #1)	H4, P4	1: _____ (BASE #1 x 2)
H2, P2	1: _____ (BASE #1 x 4)	H1, P1, A10	1: _____ (BASE #1 x 8)
A3	1: _____ (BASE #1 x 26.7)		

BASE #3 = (VPS #3 x N) ÷ 80 = _____

H8	1: _____ (BASE #1)	H4, P4	1: _____ (BASE #1 x 2)
H2, P2	1: _____ (BASE #1 x 4)	H1, P1, A10	1: _____ (BASE #1 x 8)
A3	1: _____ (BASE #1 x 26.7)		

BASE #4 = (VPS #4 x N) ÷ 80 = _____

H8	1: _____ (BASE #1)	H4, P4	1: _____ (BASE #1 x 2)
H2, P2	1: _____ (BASE #1 x 4)	H1, P1, A10	1: _____ (BASE #1 x 8)
A3	1: _____ (BASE #1 x 26.7)		

If more than one pumper is used to pump the same chemical, divide the ratio (BASE) by the number of pumpers used for that chemical.

To verify the settings, press the indicated keys.

SET To display the K FACTOR
SET + ↑ To display Volume Per Stroke (gallons or liters), VPS #1 (2 outputs)
SET + ↓ To display VPS #2 (2 out puts)
SET + ↑ or ↓ To sequence VPS #1-4 (4 out puts)
↑ + ↓ To display the PROGRAM NUMBER

To change a setting, first display it; then press **SET** and **ENTER** together until the display blinks. Then use **↑** or **↓** to set. Then press **ENTER**.

IMPORTANT! READ YOUR MANUAL

If the PROGRAM NUMBER, the K FACTOR, or the Volume Per Stroke are changed, the feed ratio will also change. **Be careful!** See the section **Setting The Outputs**, page 6, for more in formation about changing any settings, or contact the factory.

NOTE: The K FACTOR can be changed only during the first minute after power-up. (See **Setting The K Factor**, page.6)

Mounting

- Allow easy access to front panel
- Must have access to 120 VAC power outlet or directly wired.
- Close proximity to other injector components.
- Protect from direct spray

Electrical Connections

Refer to Figure 2, page 1 (2-output), or Figure 3, page 2 (4-output) for the terminal locations.

- Remove the four screws that secure the front panel.
- The flow sensor and valve outputs should be connected before wiring the power to the controller.

- The terminals on the flow sensor terminal block are labeled 1, 2, & 3, both on the terminal board and on the sensor cable. Be certain to match numbers when connecting these wires. If you need a longer cable, use the color coding to be sure that these connections are correct. **NOTE:** On 2-output models the sensor terminal block is detachable which makes connecting the cable much easier.
- On the 2-output model, valve #1 is on the left side.
- On the 4-output model, the manifold valve terminals are numbered.



WARNING! Connecting the flow sensor incorrectly can damage the flow sensor electronics.

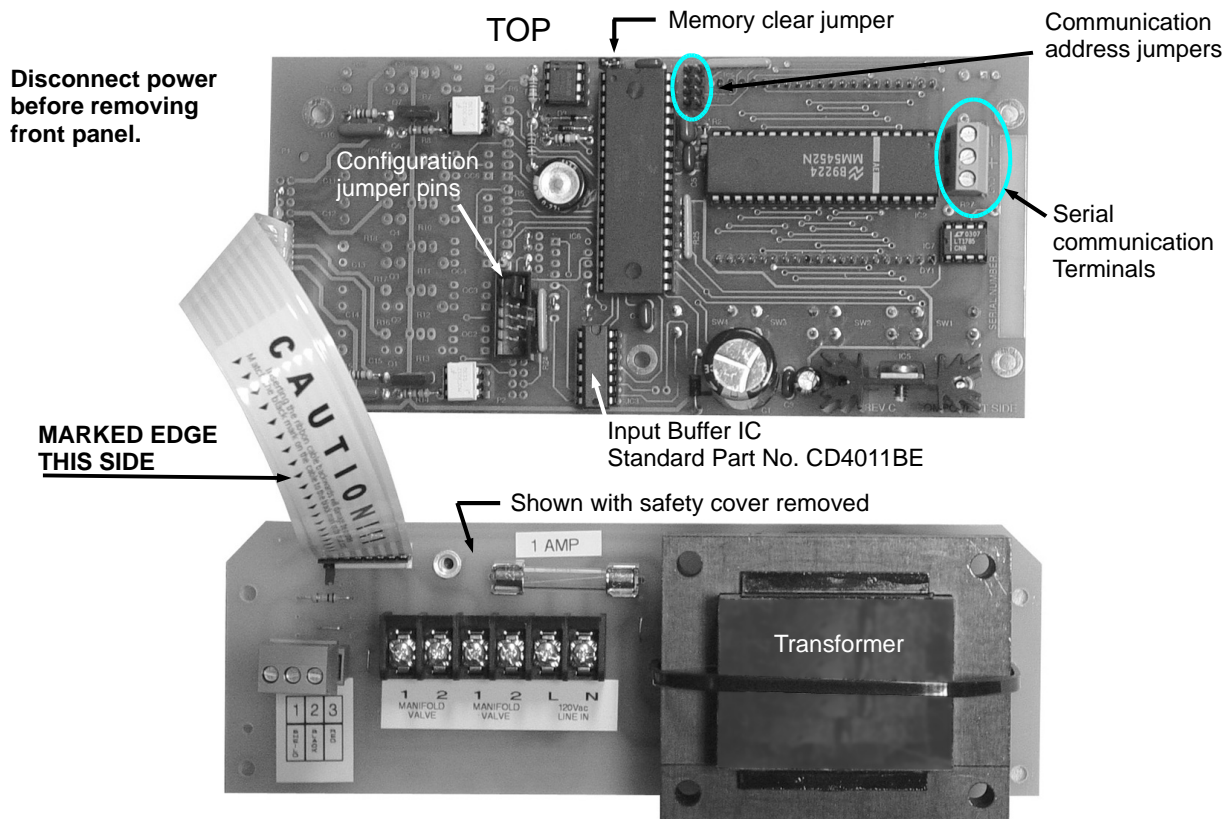

Figure 2
J Plus 2-Output front and rear circuit boards.

Setting Up the Controller

The controller must be configured in order to work properly. Units ordered with a meter from the factory should be properly configured on delivery. However it is a good idea while making the connections to double check to be sure it is configured correctly.

Setting The Jumpers

- If you do not have a multi-jet (brass) meter you will need to know the K factor of your flow meter. It should be marked on the meter. You will set your K factor later.
- Refer to Tables 2 and 3 to determine which jumpers should be set for your controller.
- Power must be off to set the jumpers.
- Remove the four screws that secure the front panel.

TABLE 1 – JUMPER POSITIONS

Jumper #	Top
5	● ●
4	● ●
3	● ●
2	● ●
1	● ●
See Figure 3 for configuration jumper location.	Bottom

- You can check or set the jumpers without disconnecting the front panel from the rear circuit board.
- If you remove the front panel, carefully remove the flat ribbon cable from the rear connector.

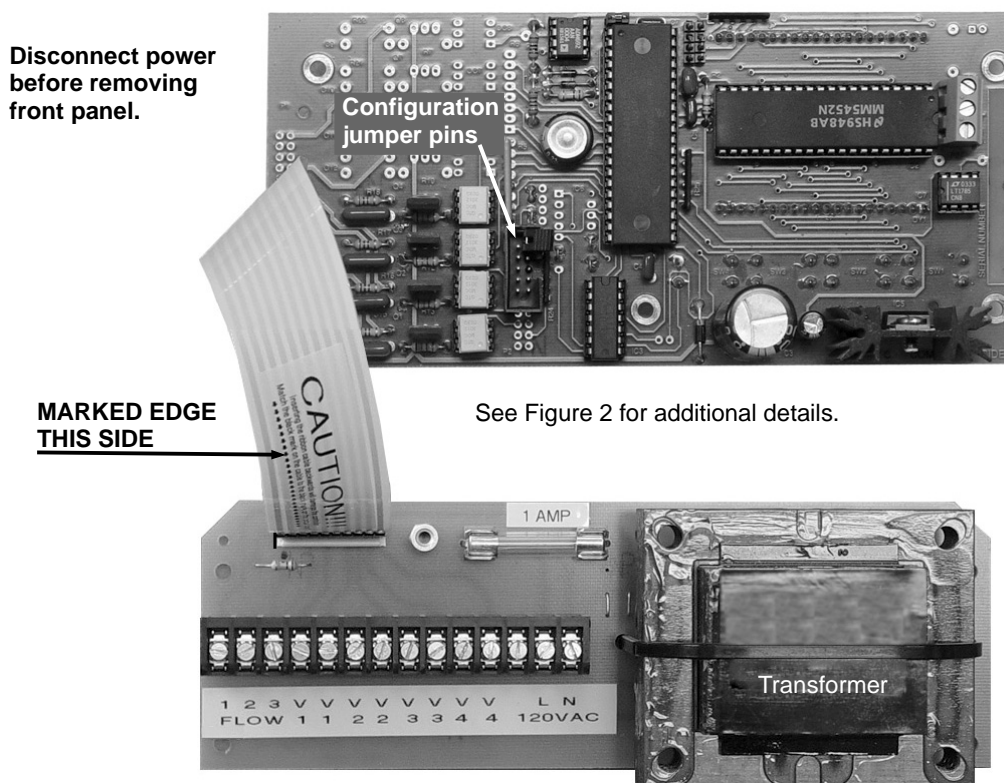

Figure 3
J Plus 4-Output front and rear circuit boards.

TABLE 2 – PROGRAMS & SETTINGS (U.S. Gallons)				
Jumpers	Program #	Meter (Flow Range)	K Factor Default (Range)	Gallons/Stroke Default (Range)
None	J* 0 or *J 0	Custom	25.00 (1.00 – 99.99)	3.12 (Variable up to 199+)
1	J* 1 or *J 1	Custom	175.0 (100.0 – 255.0)	3.12 (Variable up to 199+)
2	J* 2 or *J 2	$\frac{5}{8}$ x $\frac{3}{4}$ " Multi-jet (1/2 – 20 GPM)	234.0	1.05 (0.01 – 199.9)
1 & 2	J* 3 or *J 3	$\frac{3}{4}$ x 1" Multi-jet (1/2 – 30 GPM)	171.6	1.06 (0.02 – 199.9)
3	J* 4 or *J 4	1" Multi-jet ($\frac{3}{4}$ – 50 GPM)	83.26	2.11 (0.04 – 199.9)
1 & 3	J* 5 or *J 5	1½ & 2" Multi-jet (1½ – 100 & 2 – 160 GPM)	26.94	4.23 (0.14 – 99.9)
2 & 3	J* 6 or *J 6	1½ " Multi-jet (1½ – 100 GPM)	26.94	3.19 (0.14 – 199.9)
* Varies by software version				

TABLE 3 – PROGRAMS & SETTINGS (liters)				
Jumpers	Program #	Meter (Flow Range)	K Factor Default (Range)	Gallons/Stroke Default (Range)
None	L* 0	Custom	25.00 (1.00 – 99.99)	3.12 (Variable up to 199+)
1	L* 1	Custom	175.0 (100.0 – 255.0)	3.12 (Variable up to 199+)
2	L* 2	$\frac{5}{8}$ x $\frac{3}{4}$ " Multi-jet (1/2 – 20 GPM)	61.82	4.01 (0.06 – 199.9)
1 & 2	L* 3	$\frac{3}{4}$ x 1" Multi-jet (1/2 – 30 GPM)	45.33	4.01 (0.09 – 199.9)
3	L* 4	1" Multi-jet ($\frac{3}{4}$ – 50 GPM)	22	8.00 (0.18 – 199.9)
1 & 3	L* 5	1½ & 2" Multi-jet (1½ – 100 & 2 – 160 GPM)	7.12	4.23 (0.14 – 99.9)
2 & 3	L* 6	1½ " Multi-jet (1½ – 100 GPM)	7.12	12.07 (0.56 – 199.9)
* Varies by software version				

- Set the Jumpers across the proper pin pairs.
- If you have removed the front panel, carefully insert the ribbon cable and reattach the front panel. Be certain that the marked edge is to the left and the cable is properly seated in the connector.



Warning! Reversing or improperly connecting the ribbon cable can damage the controller when power is applied.

Powering Up The Unit

When power is applied to the unit it will display “— — — —” for a short time as it initializes and will then start displaying the flow (or **OFF** if there is no flow, or meter connected to it). If the unit has never been programmed, or if the jumpers have been changed, it will also alternately display **SEt** to indicate that it is set to the default settings in Tables 2 or 3, and must be set if you want other settings. These will display alternately until the unit has been programmed.

NOTE: *If the display shows only “— — — —” and never advances beyond that, the jumpers are set to an invalid combination. You will need to set them properly. Extra jumpers may be stored on another position by putting the jumper on only one of the pair of pins.*

NOTE: *If you have the unit set to a standard meter and you want to use the default settings, it will operate properly, but you must enter a stroke setting (even if you do not actually change it) to stop the alternate **SEt** display. See the section “Setting The Outputs.”*

Displaying The Program Number

- Press **↑** and **↓** together to display the program number and verify that it is the proper number for your meter type. If the program number is incorrect, recheck and reset the jumpers.
- Record this number on the front page of these instructions.

Setting The K Factor

NOTE: *If you have the unit set to a standard*

meter you will not be able to change the K factor.



Changing the K factor will reset the stroking rate to the default. You must re-program the Volume Per Stroke after changing the K factor to maintain the correct feed ratio.

The K factor is the the number of pulses from the meter for each unit (gallon, liter, or other volume unit) of flow. This must be set for each different meter.

NOTE: *If the K factor is expressed in pulses per gallon, the controller will display and totalize gallons; if it is expressed in other units, e.g. pulses per liter, the controller will display that unit. In fact, custom settings can be used to change the controller from one volume unit to another.*

- A variable must be displayed before it can be set. Pressing **SET** will display the K factor. Check that this also matches the value in Table 2 or 3.
- If you have the unit set to custom setting 0 or 1 you should set the K factor to that of your flow sensor.
- To change the K factor, press **SET** to display it, then press **SET** and **ENTER** together until the display starts to blink.
- Press **↑** and **↓** until you have it set properly. Once it is set, press **ENTER** once more.

NOTE: *Once the K factor has been programmed, you will only be able to change it within about a minute after power is applied. This is to protect against accidental change of this important number. If you wish to change the K factor, disconnect power for a few seconds and then reapply power and change the K factor.*

Setting The Outputs



If the controller is being controlled by a remote computer running FertiCom® software, any changes made from the front panel will be overridden by the supervisory computer at the next update.

NOTE: You may not be able to set the stroke rate at exactly to the setting you want, especially with low K factors. In these cases set it to the value nearest the desired value.

2-Output Models (Program Ver. # J* *)

- You may change the stroking rate at any time.
- A parameter must be displayed before it can be set.
- Pressing the **SET** key together with the **↑** will display the volume per stroke for the #1 output. Tables 2 & 3 show the possible range of this parameter. The increment of change depends upon the K Factor.
- Pressing the **SET** key together with the **↓** will display the volume per stroke for the #2 output.
- Once the parameter is displayed, release the arrow key and without releasing **SET** press **ENTER** until the display starts to blink.
- Then use **↑** or **↓** to set the output to the desired stroke setting or turn the output on/off. Once it is set, press **ENTER**. Or if no key is pressed, after a few seconds the unit will resume normal operation using the updated value.

4-Output Models (Program Ver. # *J *)

- You may change the stroking rate or turn an output on/off at any time.
- A parameter must be displayed before it can be set.
- Pressing the **SET** key and the **↑** or **↓** key will cause the display to cycle through the stroke parameters.
- Once a parameter has been displayed you may change it.
- To enter the change mode, without releasing **SET** press **ENTER** until the display starts to blink. Then use the **↑** or **↓** keys to set the desired value.

- Once it is set, press **ENTER**. Or if no key is pressed, after a few seconds the unit will revert to the normal mode using the updated value.
1. Display the on/off status of the #1 output (Shown as **1 on** or **1oFF**). In the change mode either the **↑** or **↓** key will toggle the output on or off.
 2. Display the volume per stroke for the #1 output. In the change mode the **↑** or **↓** key will increase or decrease the value. Tables 2 & 3 show the possible range of this parameter. The increment of change depends upon the K Factor. Exact settings may not be possible. In that case, set to the nearest value.
 3. Output #2 on/off (Shown as **2 on** or **2oFF**).
 4. Volume per stroke for #2 output.
 5. Output #3 on/off (Shown as **3 on** or **3oFF**).
 6. Volume per stroke for #3 output.
 7. Output #4 on/off (Shown as **4 on** or **4oFF**).
 8. Volume per stroke for #4 output.

Once these values have been set your controller is ready for operation.

Manually Pulsing the Outputs

At times, e.g. when priming the pumpers, useful to manually pulse the pumper outputs. You may manually pulse any of the four outputs using the following procedures:

2-Output Models

- Press and hold both **↑** and **↓** together to put the unit into the manual pulse mode. The display will show **PULS** when it enters this mode.
- While in pulse mode, pressing the **↑** key will pulse the first output; pressing the **↓** key will pulse the second output.
- After a period of time if no key has been pressed, the unit will return to normal operation. Press the **ENTER** key to immediately resume normal operation.

4-Output Models

- Press and hold both **↑** and **↓** together to put the unit into the manual pulse mode. The display will show **PULS** when it enters this mode.
- Press one of the four keys to pulse the corresponding output: The **SET** key will pulse output #1, the **ENTER** key, #2, the **↑** key, #3, and the **↓** key, #4.
- There will be a short pause to allow the operator time to open the priming vent.

NOTE: With high capacity pumpers the priming vent is on the VMC3 valve module. With standard capacity pumpers the priming vent is on the injection point fitting.

- After the pause the output will be pulsed four strokes. As the output is pulsed, the “:” symbol in the middle of the display will blink once per stroke.

- To exit the pulse mode, quit pressing keys; after a short time the unit resume normal operation. The Flow Totalizer

The flow totalizer totals up to 99,999,999. If the K factor is set in pulses per gallon, the total is in gallons. If it is in pulses per liter, the total is in liters.

Reading the Flow Total

Pressing the **↑** key displays the upper four digits. Pressing the **↓** key displays the lower four digits.

Clearing Memory

At some time you may need to clear the controller memory and reset it to the start-up defaults. To do this:

NOTE: Clearing memory will reset the flow totalizer to zero.

- Disconnect power, remove the memory clear jumper (See Figure 2).
- Wait at least fifteen minutes
- Replace the jumper, and reapply power.

TABLE 4 – TROUBLE SHOOTING

Condition	Probable Cause	Suggested Action
Unit works, but display flashes SEt .	Stroking rate not set.	Set the stroking rate (See Setting The Outputs)
Unable to set the K factor.	K factor can only be set within about a minute after power is applied.	Remove power for several seconds. Reapply power and promptly set the K factor.
Water is flowing but there is no Display.	(1) No power to controller. (2) Faulty controller.	(1) Restore power or replace fuse. (2) Replace controller.
Water is flowing but display indicates OFF .	Faulty meter sensor or cable.	See the instructions supplied with your meter.
Flow indication, but no pumping action. No waste water from pilot valve.	(1) Pilot valve not operating. (2) Faulty control board.	(1) Service pilot valve. (See separate <i>Pilot Valve and Manifold Instructions</i>) (2) Replace control board.
If you need an additional owners manual for any H.E. Anderson Company product, please visit our website at http://heanderson.com/manuals.php		

Repair

The only repair you should attempt is replacement of the fuse.

Other repairs are made by replacing complete circuit board assemblies or the complete front panel assembly. This should be done only by an authorized repair person or under the direction of our technical staff.

Fuse Replacement



Before opening the enclosure and doing anything inside you should remove ac power from the unit.

The fuse is located on the output board next to the transformer, under the protective cover. Replace with the same size and type (1 amp. AGC, Anderson P/N 15554).

Factory Service

Should you require service for your Ratio:Feeder® J Plus controller or injector, the H.E. Anderson Co. offers several flexible factory service options. Call our number listed in the front of this manual for complete information. If you need to return any parts for service or replacement, our shipping address is:

**H.E. Anderson Company
2100 Anderson Drive
Muskogee, Oklahoma 74403
USA**

Please enclose a note detailing the problems and the type of service you need. Include the name of a contact person, phone number, and the billing name and address. Any return for warranty, or credit, must have an RMA number. Contact H.E. Anderson for this number before returning.

Specifications

Power Requirements

120 VAC Standard
240 VAC and 12 VDC versions also available.

Enclosure

Gasket sealed plastic enclosure with sealed front panel.

Display

4-digit LCD

Flow Totalizer

0 – 99,999,999 gallons

Flow Meters

Multi-Jet, Paddlewheel, Turbine, or Custom type supplied by customer.

Temperature Range

33 – 105°F

J PLUS CONTROL BOX

COMPLETE BOXES
 15909S 120VAC 2 OUTPUT
 15899S 120VAC 4 OUTPUT
 17632S 12VDC 2 OUTPUT
 20476S 12VDC 4 OUTPUT

15887 J+ I/O BOARD 120VAC 2 OUTPUT
 17654 J+ I/O BOARD 12VDC 2 OUTPUT
 15588 J+ I/O BOARD 120VAC 4 OUTPUT
 20498 J+ I/O BOARD 12VDC 4 OUTPUT

16121S J+ CONTROL BOARD 120VAC 2 OUTPUT
 15933S J+ CONTROL BOARD 120VAC 4 OUTPUT
 17643S J+ CONTROL BOARD 12VDC 2 OUTPUT
 20487S J+ CONTROL BOARD 12VDC 4 OUTPUT

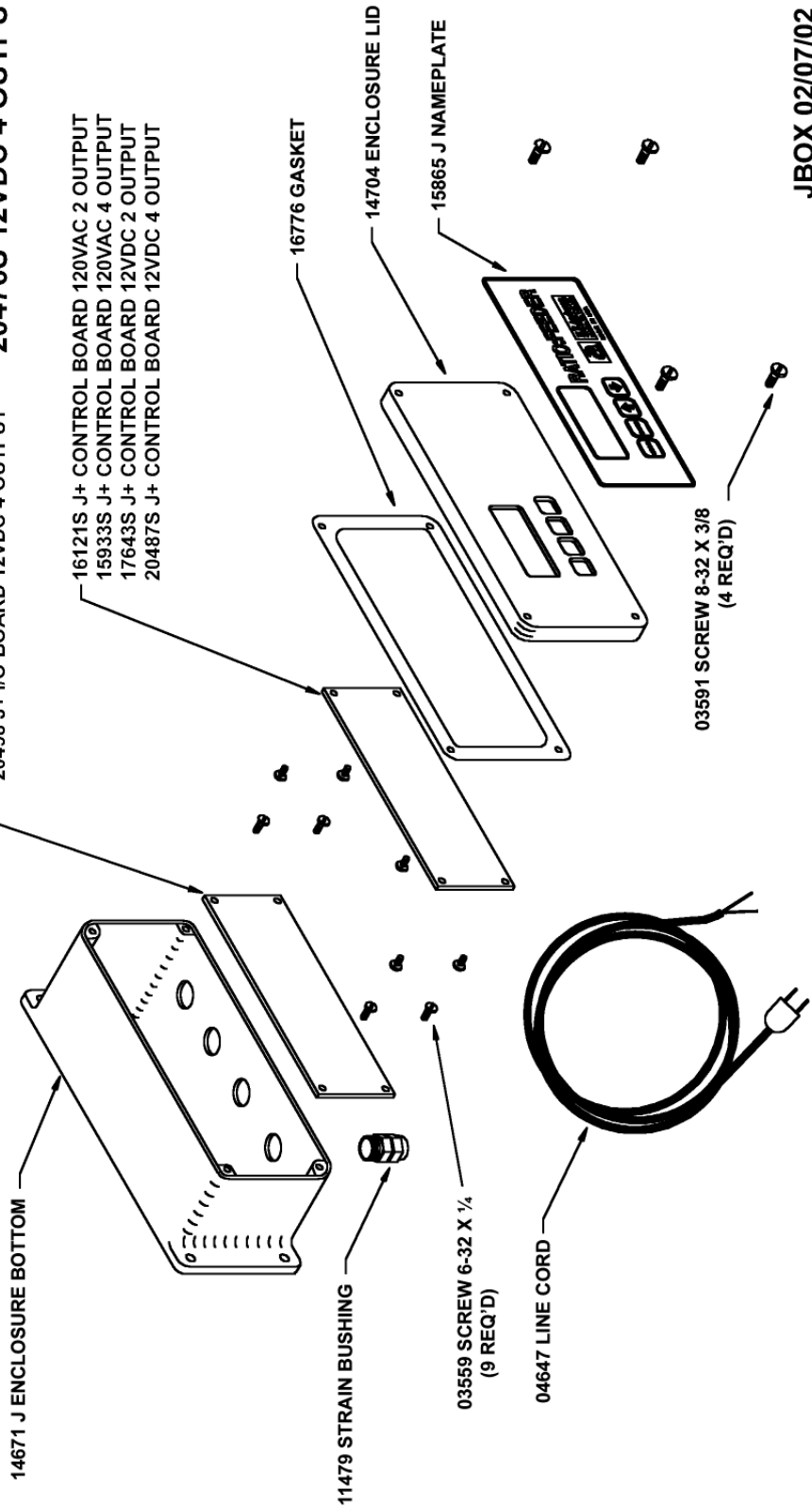

JBOX 02/07/02

RATIO:FEEDER® LIMITED WARRANTY

WHAT IS COVERED

The H.E. Anderson Company of Muskogee, Oklahoma, will make any necessary repairs and/or replace any parts of any Ratio:Feeder® product made necessary because of defects in materials or workmanship for fifteen months from date of manufacture. Warranty repairs and/or replacements will be performed without charge to the owner by H.E. Anderson Company within a reasonable time after prepaid delivery of the defective product to the H.E. Anderson Company, 2100 Anderson Drive, Muskogee, Oklahoma 74403.

WHAT IS NOT COVERED

This warranty specifically excludes failure of any parts or materials caused by chemical attack or damage caused by operation above rated capacity or pressure. Further, this warranty does not cover wear or failure caused by sand or other foreign materials which may be found in water that is passed through our products, or damage caused by freezing or exposure to water temperatures above 60 °C (140 °F).

This warranty does not cover damage caused by failure to follow prescribed installation instructions and limitations issued by H.E. Anderson Company. In addition, this warranty does not cover service adjustments, repairs, or replacements caused by misuse, negligence, alteration, accident, or lack of specified maintenance.

This warranty does not cover components used by, but not manufactured by H.E. Anderson Company, in the manufacture of our products except to the extent of said component manufacturer's warranty.

This warranty specifically excludes liability for consequential damages or for charges for labor or expense in making repairs or adjustments, or losses of time or inconvenience.

This warranty gives you specific legal rights and you may also have other legal rights which may vary from state to state. H.E. Anderson Company does not authorize any person to create for it any other obligation or liability in connection with these products. ANY IMPLIED WARRANTY APPLICABLE TO THESE PRODUCTS IS LIMITED TO THE DURATION OF THIS WARRANTY. H.E. Anderson Company shall not be liable for consequential damages resulting from breach of this written warranty.

NOTE: Some states do not allow limitation on how long an implied warranty will last or the exclusion of limitations of incidental or consequential damages, so the above limitations or exclusions may not apply to you.

WHAT TO DO IF THERE IS A QUESTION REGARDING WARRANTY

- 1) Promptly notify the consumer adviser at H.E. Anderson Company by telephone at 800-331-9620 or 918-687-4426.
- 2) Confirm the report in writing (or via FAX at 918-682-3342) to the H.E. Anderson Company, stating the circumstances surrounding the problem.

PURCHASER'S OBLIGATION

- a) Purchaser must give H.E. Anderson Company immediate written notice on discovery of defect.
- b) Purchaser must pay for shipment of the defective product to the H.E. Anderson Company, 2100 Anderson Drive, Muskogee, Oklahoma 74403.