

H8 Start Guide

Part# H8-HD

UNPACKING

Please open and inspect your package upon receipt. Your package was packed with great care and all the necessary packing materials to arrive to you undamaged. If you do find an item that is broken or damaged, you must contact the delivering carrier to report the claim.

GETTING TECHNICAL ASSISTANCE

The H.E. Anderson Company is dedicated to assisting our customers with installation and use of our products. Our technical staff are available each weekday from 8:30am to 4:30pm central time. You may call us toll free at **1-800-331-9620** from anywhere in the U.S.A. and Canada. If no one is available, we will promptly return your call.

Before you call, we suggest that you review this manual. You may find the answer to your question here. But even if you do not, reviewing the manual will help us to help you.

There is some information you should have available when you call. You should know the model and serial number of your control unit. Also, you should note the number of pumpers of each type, and their model numbers (found under the adjustment knob, stamped into the casting). We may not need all this information, but having it available at the start can sometimes save a lot of time and trouble for you.

If you need an additional owners manual for **any** H.E. Anderson Company product, please visit our website at <http://heanderson.com/manuals.php>.

Specifications:

Maximum operating pressure: 125psi

Maximum stroke rate: 40 strokes/minute

Minimum operating pressure: 30psi

Diaphragm material: EPDM rubber

Warning: Check to make sure the pump head screws have not been loosened during shipping. Failure to do so can result in chemical spray and leaks.

Warning: Use extreme caution and use appropriate personal protection equipment (goggles, chemical suit, etc.) any time contact with chemical might occur.

Note: The performance of the H8 pumper will be affected by the way it is installed. The pumper will pump faster and require less waste water if the hoses connecting the pump to the manifold and the Injection Point Fitting (IPF) are short. Also, the number of pumpers connected to the manifold can affect the maximum rate the pumpers can operate. Refer to the installation drawing for more detail.



Table of Contents

H8-HD Contents:.....	2
Installation Instructions:.....	2
Operating Considerations.....	4
Replacing a Chemical Side Diaphragm.....	5
Calibrating the Pump Head.....	6
Alternate calibration method.....	7
Typical H8-HD and Manifold Installation.....	8
Exploded View Diagram.....	9

H8-HD Contents:

Part #	Description	Quantity
48505	Pumper H8 Standard PVC	1
20976	VMC3 Complete	1
21209	VMC3 IPF	1
09573	Screw 1/4-20 x 2-1/4 SS Pan Head	2
09432	Hose Red 3/4 Inch Bulk	4 ft.
08070	Hose Clamp 3/4	2
12063	Hose 1/2 Clear Braided Bulk	8 ft.
11717	Hose Clamp 1/2 Inch SS	3
13855	Strainer HC Suction Complete	1
22306	Screw 1/4-20 x 3/4 SS Hex	2
04599	Nut 1/4-20 Hex SS	2
22091	Stand H8	1

Installation Instructions:

1. Refer to the installation drawing for a general overview of how the H8 should be installed.
2. Unpack the contents and make sure all the parts are present.
3. Ensure the screws on the chemical side of the pump have not become loose during shipping. The chemical side of the pump is the side with the calibration sticker. If the pump head is loose, chemical can spray out when the pump is used. Use a 7/16" wrench to tighten the 6 hex head bolts and use a 5/32" allen wrench to tighten the 2 socket head screws.
4. Install the pump onto the stand using two 1/4-20 x 3/4" hex head screws and (2) hex nuts. Use a 7/16" wrench to tighten the bolts.



5. Install the gray Check Valve Module (VMC3) onto the back of the H8 using two 1/4-20 x 2-1/4" screws and a flat head screwdriver. Make sure the o-ring is present and between the VMC3 and the pumper before tightening the screws.

Warning: Make sure the Ratio:Feeder® system is powered off and no water is supplied to the pilot valve before proceeding.

6. Connect the H8 to the pilot valve manifold by attaching one end of the red 3/4" hose to the brass hosebarb on the front of the H8. Use a 3/4" hose clamp to secure the hose to the hosebarb. Attach the other end of the hose to the hosebarb on the side of the manifold and use another 3/4" hose clamp to secure the connection.

Note: The H8 pumper will have less waste water and pump faster if the connecting hose is short. Make sure there are no kinks or sharp bends in the hose.

7. Install the IPF in the water line. Be sure to install the IPF on the downstream side of the water meter. Injecting chemical upstream of the meter can damage the meter.
8. Measure and cut a piece of 1/2" braided clear hose to connect the top hosebarb on the VMC3 to the hosebarb on the IPF. Secure both ends to the hosebarbs using 1/2" hose clamps. Ensure the hose clamps are tight to avoid chemical spraying out when the pump is operating.
9. The suction strainer/foot valve can be used to keep the pump primed and also prevent sediment from clogging the pump. To install the suction strainer/foot valve, measure and cut a piece of hose long enough to go from the bottom hosebarb on the VMC3 to the bottom of the chemical tank.
10. Connect an end of the 1/2" braided clear hose to the bottom hosebarb on the VMC3 module on the back of the H8. Use a 1/2" hose clamp to secure the connection.
11. Insert the hosebarb on the suction strainer/foot valve into the other end of the 1/2" braided clear hose. Drop the suction strainer/foot valve into the chemical tank and make sure the foot valve is completely submerged in chemical before attempting to prime the pump. No hose clamp is required to secure the foot valve to the hose as long as the hosebarb is fully inserted into the hose.

Warning: Make sure the priming valve on the side of the VMC3 is closed before operating the pumper.

12. If the rest of the Ratio:Feeder® system has been installed (refer to appropriate manual for instruction) check all connections before operating the pumper.



13. Supply chemical to the VMC3 on the H8 and turn on the J control box. Make sure the proper J controller is set to the proper Gallons per Stroke (GPS). The H8 is large enough that the pump should prime within a few strokes without the help of the priming valve. The length of hose and/or pipe between the chemical tank and the pumper can affect the length of time required to prime the pump.

Warning: Use appropriate personal protection equipment (goggles, chemical suits, etc.) any time there might be contact with chemicals.

14. If the pump takes more than a few strokes to prime, attach a piece of 1/4" clear hose to the priming valve on the VMC3 and feed the other end of the hose back into the chemical tank. Open the priming valve and continue to operate the pump to prime it. Chemical can rapidly shoot out of the priming valve if no tubing is connected when the pump strokes.
15. Once the pumper had been primed the dial can be adjusted from 10 to the desired setting. Use the set screw on the side of the stroke control assembly to prevent vibration from moving the dial setting.

Operating Considerations

Warning: Never transfer the suction line of a feeder pumping acids or strong alkalis to a container of water. This can cause dangerous heat generation which may destroy your pump and/or cause personal injury. Always use safety equipment when working with acids or strong chemicals.

Note: Do not disassemble the pumper until testing and trouble shooting indicate that you need to do so. There is normally very little maintenance or service required internally.

Note: Replacing a ruptured chemical side diaphragm quickly can prevent further required maintenance. If a ruptured chemical side diaphragm is not replaced promptly, the chemical can damage other internal pumper parts.

Note: Most pumper problems encountered involve faulty or clogged check valves or worn out pumper diaphragms. Servicing valves do not require the pump head to be disassembled. Refer to the High Capacity Valve Manual for instructions of how to service the VMC3 valve module.

Note: Diaphragm failures usually result in liquid seeping from the bottom of the pump head. Water is usually present when a water side diaphragm ruptures and chemical is usually found when a chemical side diaphragm ruptures.



Replacing a Chemical Side Diaphragm

1. Remove the hose from the VMC3 that connects to the IPF. Wear appropriate personal protection equipment and use caution around dangerous chemicals.
2. Flush out the VMC3 by connecting a garden hose to the foot valve. Remove the foot valve from the chemical tank and unscrew the gray PVC body from the black hosebarb assembly. A garden hose can be screwed directly into the black hosebarb assembly. Turn on the garden hose to flush the foot valve and the VMC3 with water.
3. Remove the hose connection the VMC3 to the foot valve.
4. Remove the VMC3 from the pump head using a flat head screwdriver to unscrew the two screws. Be careful not to lose the o-ring that seals the VMC3 to the H8.
5. Make sure the H8 dial is set to 10.
6. Use a 5/32" allen wrench to remove the two socket head screws at the top of the pump head.
7. Use a 7/16" wrench to remove the remaining 6 bolts holding the head on the H8.
8. Turn the stroke control shaft until the H8 is on a setting of 1. This will make it easier to remove the chemical side diaphragm.
9. Twist the chemical side diaphragm in a counter-clockwise fashion until it falls loose from the H8. The diaphragm connecting shaft might unscrew with the chemical side diaphragm or it might stay attached to the water side diaphragm. Both cases are acceptable.
10. Inspect the diaphragm for unusual wear signs that might lead to premature failure of the new diaphragm.
11. If the stud is still in the old chemical side diaphragm, remove it and insert it into the new diaphragm. Assemble the diaphragm connecting shaft as it was before and screw the new chemical side diaphragm onto the diaphragm connecting shaft until it is hand tight.
12. Set the H8 to a dial setting of 10 and reassemble the plastic pump head and metal plate. Tighten them down using the 6 hex head bolts and 2 socket screws.
13. Reassemble the VMC3 and reconnect the hoses to the foot valve and the IPF using hose clamps to secure the connections. Reassemble the foot valve as it was before and put it back into the tank.
14. The pump head must be calibrated after every diaphragm replacement. Refer to the pump head calibration instructions on how to do this.

Note: Call H.E. Anderson Co. if you need to replace a water side diaphragm.



Calibrating the Pump Head

1. Obtain a graduated beaker or cylinder with milliliter marks. A graduated beaker (Part # 09888) is shipped with all manifolds sold by H.E. Anderson.

Note: The easiest way to calibrate the pump head is to use a scrap piece of 1/2" braided clear hose (Part #12063) that is a few feet long.

Warning: Use extreme caution and use appropriate personal protection equipment (goggles, chemical suit, etc.) any time contact with chemical might occur.

2. If a spare piece of 1/2" clear braided hose is available, disconnect the clear braided hose from the bottom hosebarb on the H8. Connect the spare piece of hose and secure it with a hose clamp. Fill the graduated cylinder or beaker with water and submerge the end of the clear braided hose into the beaker. If no spare piece of hose is available, pull the suction hose out of the chemical tank using care not to contact any chemical. Remove the suction strainer and submerge the end of the hose into the graduated beaker.
3. Turn the stroke control shaft on the pumper counter-clockwise until it is adjusted all the way out. Do not force the stroke control shaft once it has reached its limit.

Warning: The dial should only be adjusted when the manifold is energized and allowing water into the pumper. Turning the dial in when the pumper is not energized can damage the stroke control shaft.

4. Prime the pump head by using the J Control box to pulse the output. To do this press and hold both the up arrow and down arrow together to put the unit into manual pulse mode. The display will show 'PULS' when it enters this mode. Pressing the up arrow on the J Controller will pulse the first output and pressing the down arrow will pulse the second output. After a period of time if no key has been pressed, the unit will revert to normal operation. Pressing the ENTER key will cause the unit to immediately revert to the normal mode. Pulse the output for the manifold that is connected to the pump head that you are attempting to calibrate until there is no air left in the suction line. The graduated beaker might need to be refilled during priming to ensure no air is sucked into the hose.
5. After the pump has been primed, adjust the water level in the beaker to a known level such as 400mL for example. Make sure at least 80mL can be drawn out of the beaker so the pump does not lose its prime.



6. Stroke the valve once to determine how much the pumper is currently pumping per stroke. If the pump is properly primed and the stroke control shaft is moved all the way out, it should pump more than 80mL. If it does not than something is wrong with the pumper or the check valves.
7. Adjust the stroke control shaft in or out until 80mL is drawn out of the beaker. Once the stroke control shaft has been adjusted so the pumper draws 80mL per stroke, loosen the screw that holds the black dial scale holder to the aluminum bracket on the front of the pump head enough that the dial scale holder can be moved up and down but stays in place. Lift the dial scale and adjust the dial gear so the 10 mark is selected in the window of the cover.
8. Lower the dial scale until the dial gear meshes with the gear on the stroke control shaft. Tighten the screw once the gears are meshing and the dial scale has been set to 10.
9. The pumper should now be recalibrated to pump 80mL per stroke and can be put back into service by reattaching the all the hoses that have been removed and setting the stroke control shaft on the proper number.

Alternate calibration method

1. There is a much easier but far less accurate way to calibrate the pumper. This method is only recommended to calibrate the pumper roughly close to the proper setting at 10. It should only be used when time is short and the pumper should be calibrated the proper way as soon after as possible. Begin by turning the stroke control shaft counter-clockwise all the way out until it will no longer turn. Do not however, force the stroke control shaft because this can damage the pump head.
2. Next, turn the stroke control shaft clockwise approximately 3/4 of a turn.
3. Loosen the screw that holds the black dial scale holder to the aluminum bracket on the front of the pump head. Lift the dial scale up and turn the dial scale gear until 10 is selected in the window.
4. Lower the dial scale until the dial gear meshes with the gear on the stroke control shaft. Tighten the screw once the gears are meshing and the dial scale has been set to 10.
5. The H8 should now pump roughly 80mL per stroke but should be calibrated the proper way a soon as possible.

Typical H8-HD and Manifold Installation

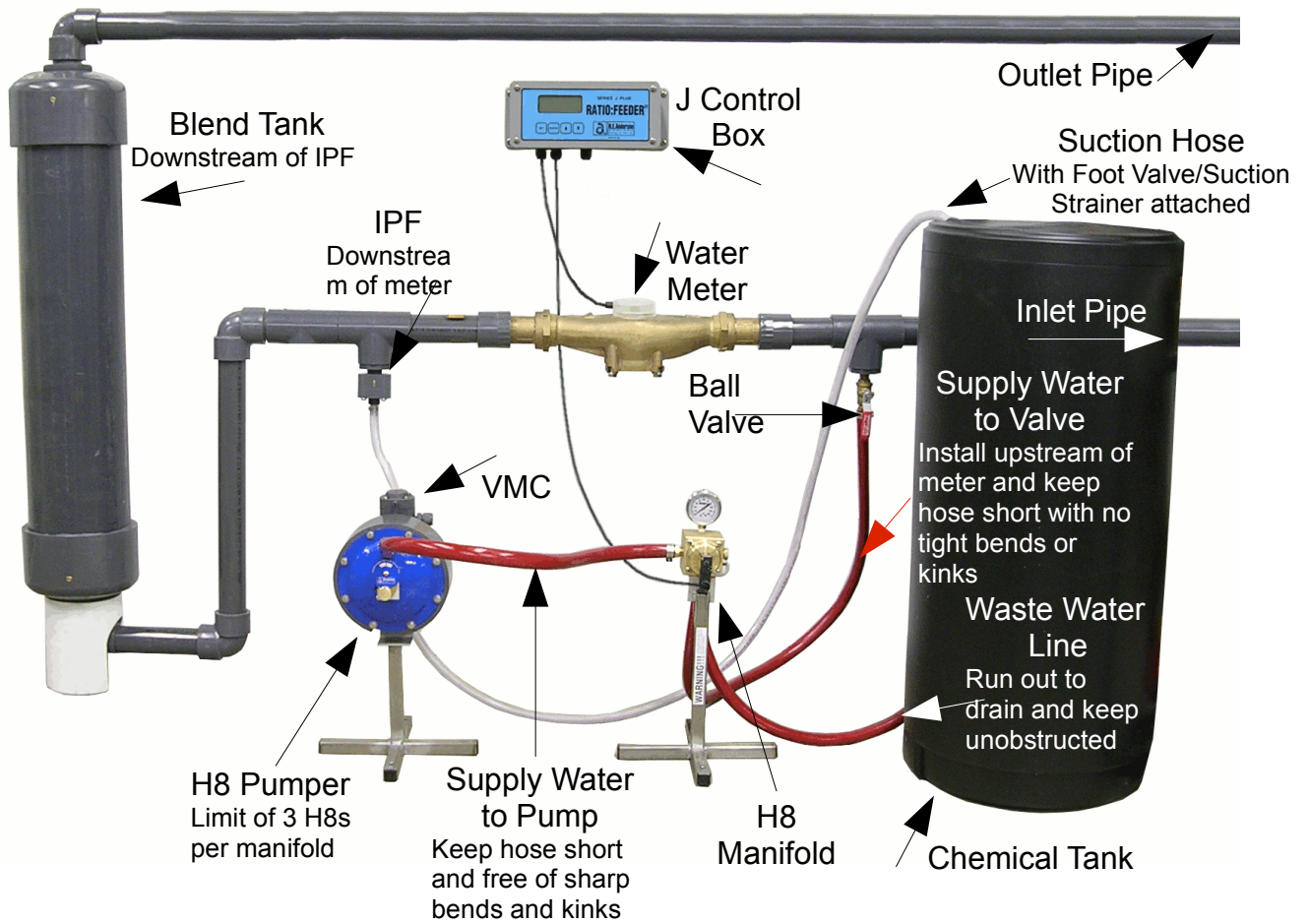

Note: The H8 can be connected to a traditional manifold by removing one of the 1/2" plugs from the multiadapter and inserting a hosebarb.

Exploded View Diagram

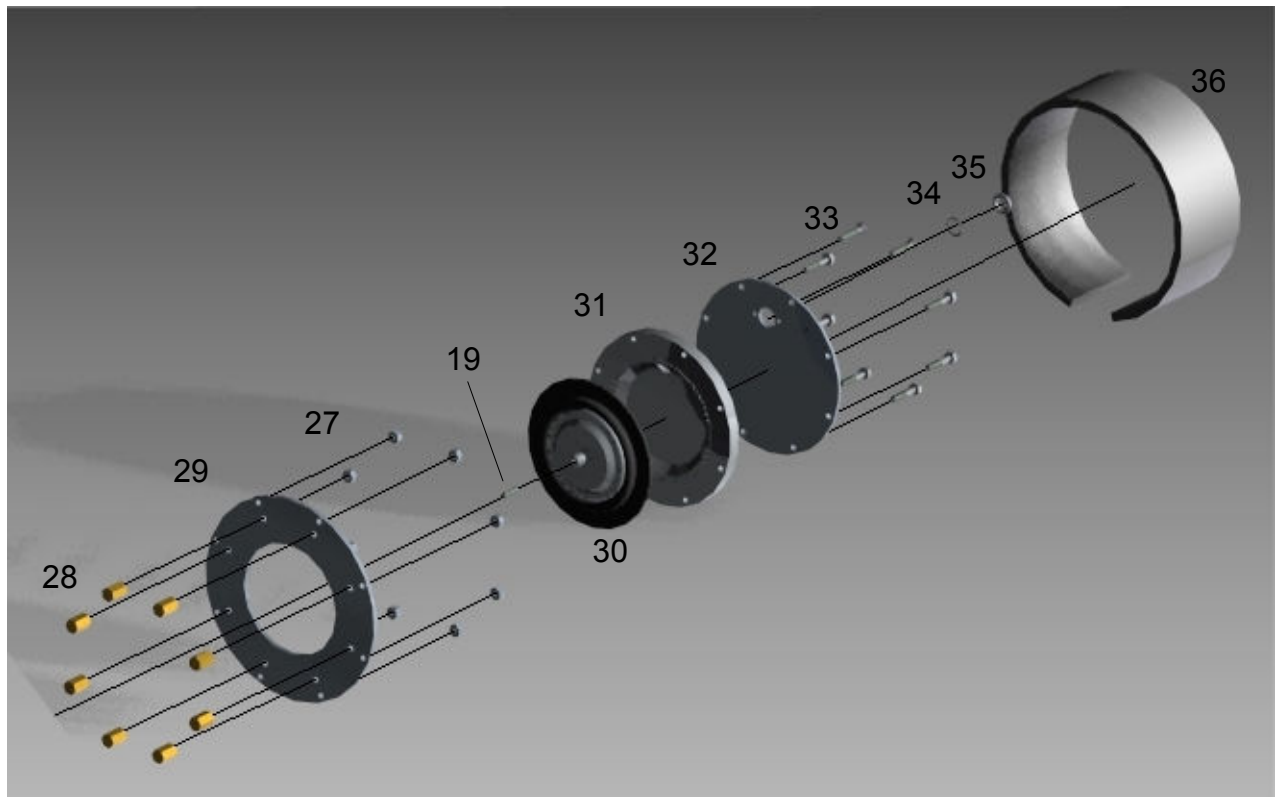
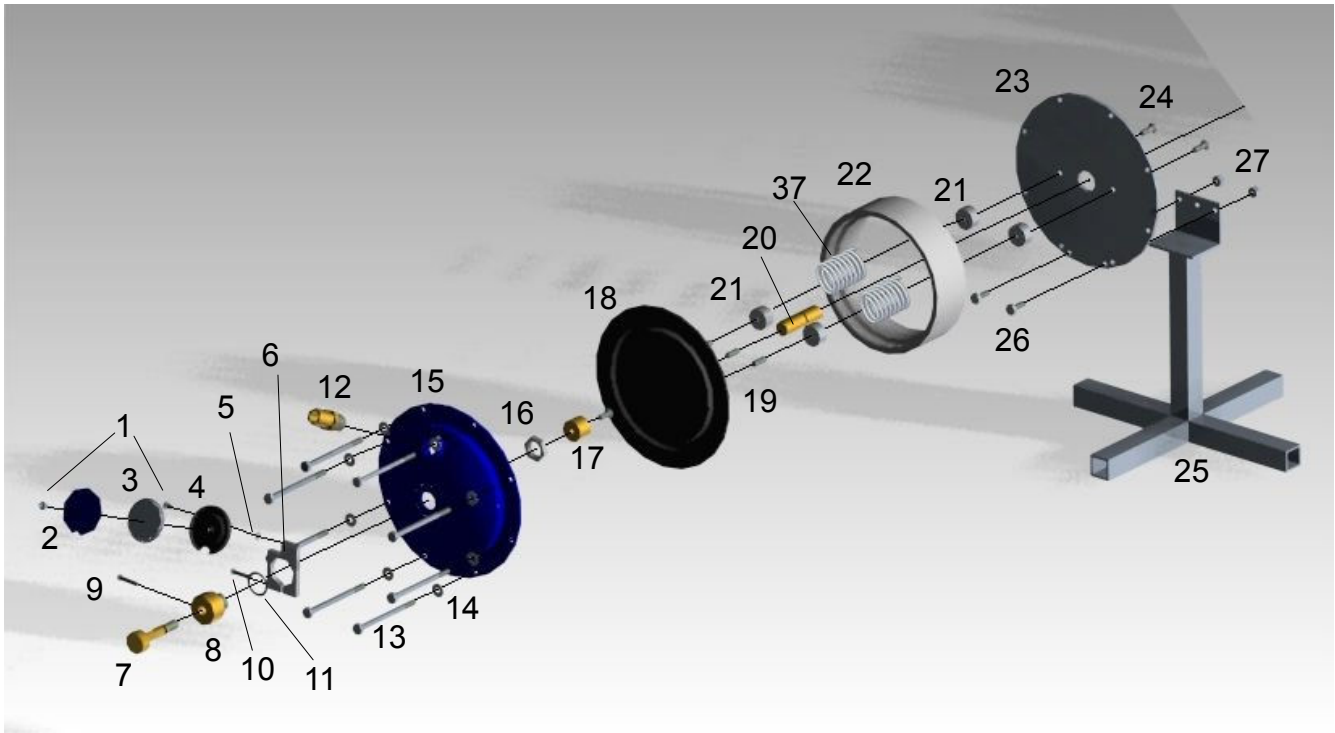

Part Description	Part Number	Quantity
1. Dial Gear Screw	01371	2
2. Dial Cover	01412	1
3. Dial Gear	01339	1
4. Dial Gear Holder	00125	1
5. Dial Gear Washer	12253	1
6. Dial Holder Mtg Bracket	22108	1
7. Stroke Control Shaft	01347	1
8. Stroke Control Shaft Holder H8	22009	1
9. Screw 8-32 x 1/2 Nylon Ph	20132	1
10. Screw 10-32 x 1" SS	22116	1
11. SCS Holder O-Ring H8	22223	1
12. Hosebarb Brass 1/2NPT x 3/4	09854	1
13. Bolt H8 Flange 1/4-20 x 4 HX H	22231	8
14. Washer 1/4 Flat SS	04605	8
15. Flange H8	22182	1
16. SCS Holder Retaining Nut H8	22017	1
17. SCS Pad H8	22025	1
18. Diaphragm #8 Water Side	22132	1
19. Stud #1-2-4T4	01181	4
20. Diaphragm Connecting Shaft H8	22041	1
21. Spring Holder PVC H8	22059	4
22. Cylinder PVC H8	22075	1
23. Spring Holder Plate H8	22174	1
24. Screw 1/4-20 x 1/2 SS Flat Skt	22281	2
25. Stand H8	22091	1
26. Screw 1/4-20 x 3/4 SS Hex	22306	2
27. Nut 1/4-20 Hex SS	04599	10

Part Description	Part Number	Quantity
28. Brass Standoff H8	22033	8
29. Chemical Seal Ring	22166	1
30. Chemical Side Diaphragm H8	09391	1
31. Pump Head PVC H8	22067	1
32. Pump Head Plate H8	22158	1
33. Screw 1/4-20 x 1-1/4 SS Hex	22257	6
34. O-Ring Viton	01686	1
35. Pump Head Plate Spacer H8	22083	1
36. H8 Cover	21190	1
37. Spring H8	22273	2